

FACT SHEET

PLASTICS GRANULATOR

A plastics granulator shears and smashes scrap plastic to make granules for moulding. Heavy knives are bolted to a rotor turn at high speed, close to a fixed anvil. Plastic offcuts from pressed products are loaded into a small granulator beside the press. Larger quantities are brought to a large granulator.

Granules pass through a screen which limits their maximum size. Granules that fall through the screen are collected for moulding.

FIGURE 1: PLASTIC GRANULATOR

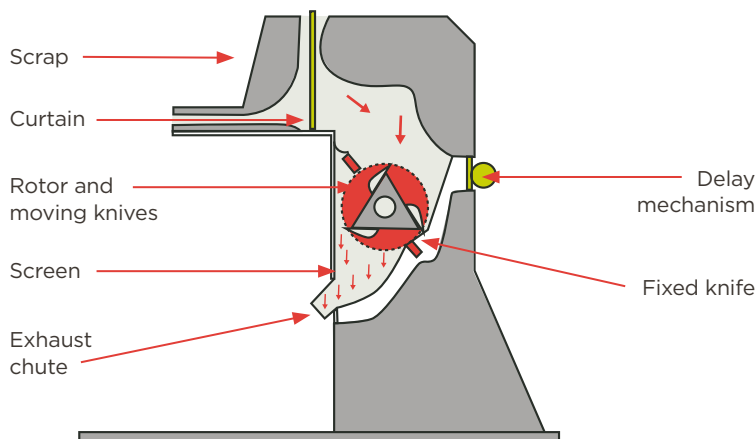

HAZARDS:

- > Contact with knives
- > Entanglement
- > Contact or impact from ejecting plastic
- > Dust
- > Fire & explosion
- > Noise
- > Slips, trips and falls
- > Entanglement from unexpected rotor movement (during maintenance, cleaning & repairs)
- > Collision between moving and fixed knives

PPE:



FIGURE 2: SIDE ELEVATION OF PLASTICS GRANULATOR

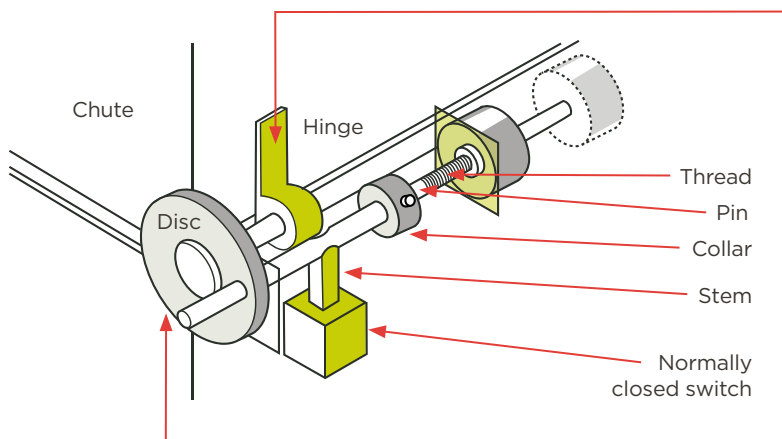

The delay mechanism and hinge are secured to the chute.

Unscrewing the bolt opens the switch and power to the motor, then allows the disc and attached chute to pivot open.

The time taken to unscrew the bolt prevents access to the spinning rotor until after the power is shut off and movement stops.

TASK - LOAD & UNLOAD

Hazard	Harm	Controls
Contact with knives while handling rotors	> Deep cuts or amputation	<ul style="list-style-type: none">> POWER the cutters from interlocked circuits to ensure they do not move until guards are closed.> ENSURE that the size and shape of the chutes prevents reach to the knives.> USE a paddle to push items into the chute.> CUT material (like plastic sheet) to a MAXIMUM length of 1.5 metres, to prevent entanglement.> NEVER stand on raised supports that increase the chance of reaching the cutters.> KEEP guard interlocks safely maintained.

Rotors are somewhat sluggish, revolving for several seconds after power is turned off. Operators can slip and make contact with sharp knife edges while handling rotors.

TASK - BREAKING DOWN PLASTICS

Hazard	Harm	Controls
Entanglement when feeding long lengths of material into chute	> Hands and arms pulled into chute	<ul style="list-style-type: none">> REDUCE length of material for granulation to a maximum of 1.5 metres.
Contact or impact from ejecting plastic	<ul style="list-style-type: none">> Cuts> Bruising	<ul style="list-style-type: none">> USE flexible curtains in the throat of the chute to minimise the chance of thrown items. Curtains MUST allow entry of items for granulation.> WEAR a face guard as protection from ejected items.

Items that contact the knives and are thrown back from the chute can be hazardous.

OTHER (NON-MECHANICAL) HAZARDS

Hazard	Harm	Controls
Dust	<ul style="list-style-type: none">> Eye irritation or damage> Breathing problems, lung damage or cancer> Worsening of existing health problems	<ul style="list-style-type: none">> CONTAIN plastics dust as much as possible during granulation.> CLEAN plastic dust from surfaces where it lands. Blowing dust with compressed air is NOT acceptable.> Handling and storage processes MUST MINIMISE spills and dust.> PROVIDE adequate ventilation/extraction.> ALWAYS USE respiratory protection.> ALWAYS USE eye protection.



Plastics dust not contained during and after granulation could cause fire and explosion.

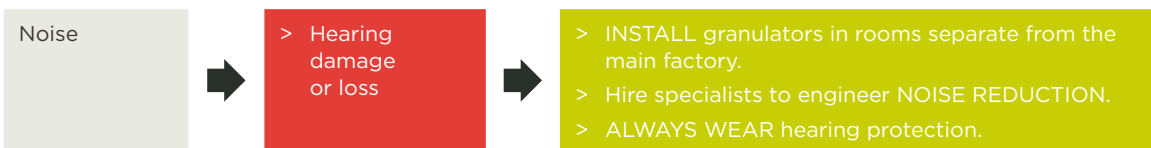

A safe level of noise over an eight hour day is 85dB(A). A plastics granulator may exceed this noise intensity.

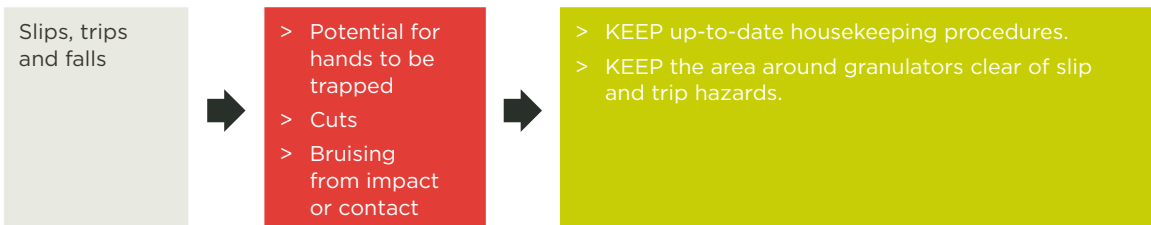

TASK - MAINTENANCE, CLEANING & REPAIRS



If additional safeguards are required they MUST be fitted by a competent person working to recognised safety standards. Instructions MUST BE provided in a language that operators understand.

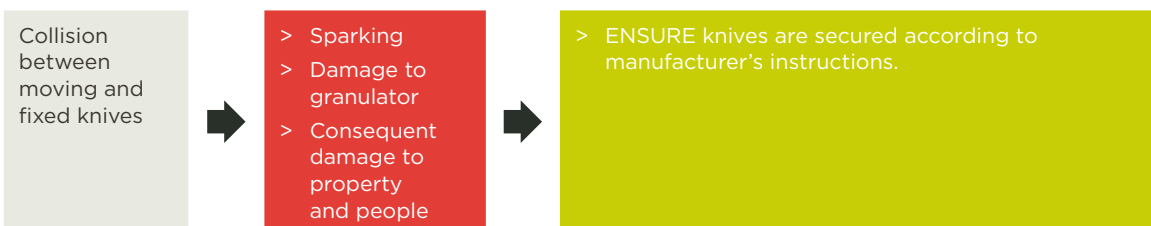

References, current standards and further information can be found on the Safe Use of Machinery project page at: www.worksafe.govt.nz

PUBLISHED: APRIL 2014. CURRENT UNTIL REVIEW IN 2017